

1.2GHz DRFM (Digital RF Memory)

Features

- Instantaneous bandwidth: 1.2 GHz
- Sampling: 4-bit phase
- Update rate: 720 MHz
- Throughput delay: <100 nanoseconds
- Phase modulation and P/N noise generation
- 50dB input dynamic range
- Operating temperature range -40C to 70C*
- Two single slot 6U/C VME 64X modules
- VME P2 Real time and RF Memory control
- Frequency, Pulse-Width, Time of Arrival

* Contact factory for extended temperature range



Item Description

LNIX's DRFM offers truly advanced capability for electronic countermeasures. LNIX's proprietary custom 0.18 micron CMOS ASIC comprises the baseband component of a phase-sampled DRFM. The ASIC includes the phase-sampling circuit, digital processing, signal reconstruction and digital to analog outputs. Combining the ASIC with our line of UP/Down Converters, LNIX offers operation over the 2-18 GHz RF band.

The ASIC kernel is a key element to LNIX's DRFM products. Currently, our VME Dual DRFM is user programmable and offers four modes of operation, idle, delay, real-time, and re-circulation. The architecture readily accommodates user inputs for RGPO, VGPO, noise and coherent techniques. Standard units have an LO synthesizer for each channel that can be user specified to operate at a frequency in the range of 2.8GHz to 3.0GHz. Call for other options, detailed performance data, application information, price and delivery.

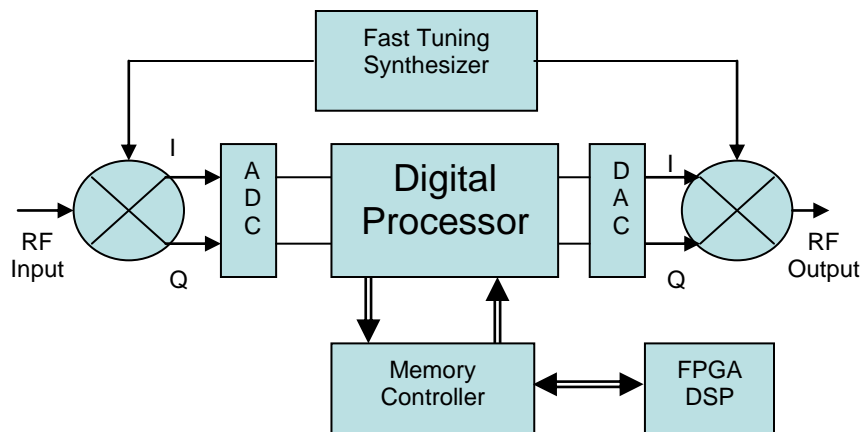

Block diagram of a typical DRFM subsystem

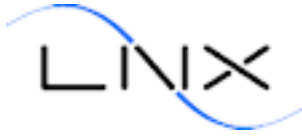

8B Industrial Way
 Salem, NH 03079
 Tel: (603)898-6800
www.lnxcorp.com
 Sales@lnxcorp.com

LNX DRFM SPECIFICATION

DRFM Parameter	Specification
Instantaneous Bandwidth	1.2 GHz
DRFM IF Center Frequency	Standard: 2.8GHz to 3.0GHz, call for other frequencies
LO IF	Internal – Independent for each channel (2)
Input Dynamic Range	-50 dBm to 0 dBm
Output Power	0dBm
Flatness	< ± 3 dB over 1.2 GHz band
VSWR	2.0:1 max
Sampling	4 bits phase
Sampling Rate	720 MHz I/Q
Output Spurious	>20 dBc typical over 100% of band >30 dBc within 1 MHz of desired for 97.5 % of band
Minimum input pulse width	40 nsec (typical)
Output Pulse width	Follows input signal to CW in recirculation mode
Recirculation phase correction	22.5 degrees
Thru delay (Memory bypass)	<55 nsec
Thru delay (Memory)	<100 nsec
Delay resolution	5.56 nsec
Write modes	Internal detect, external detect
Memory size	> 1msec, configurable as multiple files
Environment	-40 to +70 degrees C (extended range avail.)

Please contact LNX for additional information on this and other products.
 Specifications are subject to change without notice.